

LogoLED 500

one4all





La versione a LED è ideale per proiezioni su pavimenti e facciate di piccola e media grandezza, ha un LED ad alta potenza da 45.000 lumen con una durata di 50.000 ore senza dover cambiare il LED. Peso 16 kg. IP65 (concepito espressamente per un utilizzo in esterno senza l'uso di coperture antipioggia)



The LED version is the ideal one for projections on floors and small and mean façades, it has a high power LED of 45.000 lumen, with a duration of 50.000 hours without changing the LED. Weight: 16 kg. IP65 (specifically designed for the use in exterior without the rain cover)

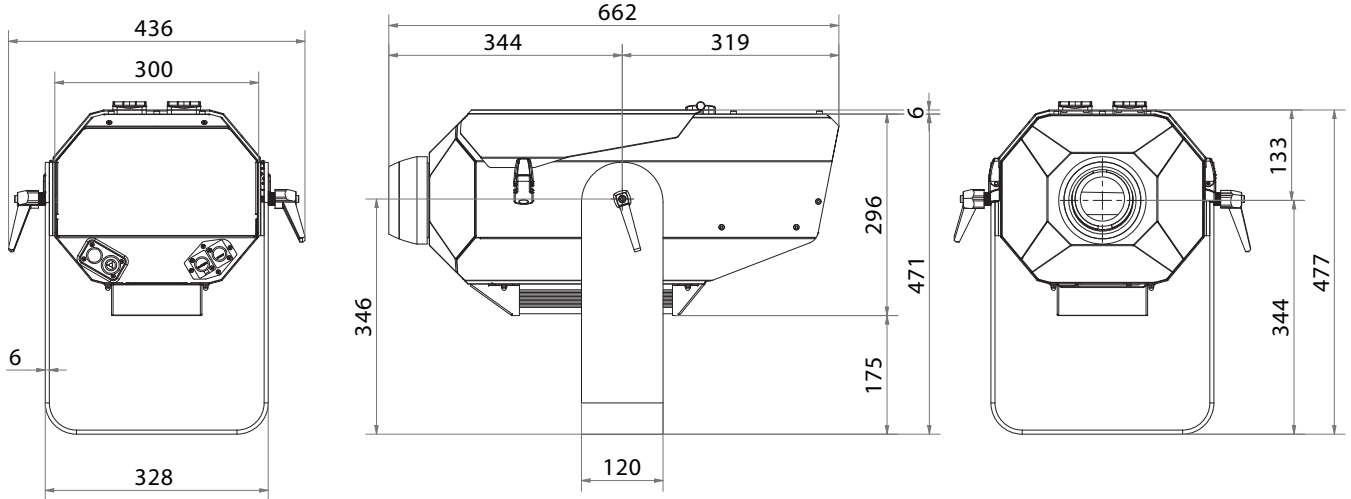

LOGO LED 500W DATI TECNICI

- Massimo consumo elettrico 500 W / 2,3 A
- Gamma voltaggio: 220-240V / 50 - 60Hz (altri voltaggi disponibili su richiesta)
- Sorgente luminosa: Cob LED 45.000 Lumen, 20.000 Output Lumen, 5.300K
- Dimmer interno da 10% a 100%
- Vita media sorgente LED: 50.000 ore
- Protezione: IP 65
- Classe di isolamento: 1
- Cavo di alimentazione con connettore PowerCon True. Per la connessione fino a 5 proiettori per ogni linea
- Conforme allo standard di sicurezza CE
- Temperatura operativa: da -25°C (-13°F) a +45°C (113°F)
- Peso: 16 kg



LOGO LED 500W DATA SHEET

- Max power consumption 500 W / 2,3 A
- Voltage range: 220-240V / 50 - 60Hz (other voltages possible on request)
- Light source: Cob LED 45.000 lumen, 20.000 Output Lumen, 5.300K
- Inside dimmer: from 10% to 100%
- LED average lifespan: 50.000 hours
- Protection rating: IP 65
- Electrical class: 1
- Power cord with PowerCon True Connector (up to 5 LOGO LED connectable)
- Meets CE safety standard
- Operating temperature: -25°C (-13°F) to +45°C (113°F)
- Weight: 16 kg

OTTICHE DISPONIBILI

Rapporto di proiezione sul diametro da 1:1 a 10:1

AVAILABLE LENSES



Projection ratio on diameter from 1: 1 to 10: 1

ACCESSORI ED EFFETTI DINAMICI
ACCESSORIES AND DYNAMIC EFFECT





 staffa da palo
 pole / balcony
wall bracket

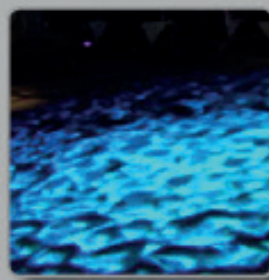

 Effetto Fuoco
 Fire effect



 Effetto Acqua
 Water effect



 Prisma Color
 Prism Color

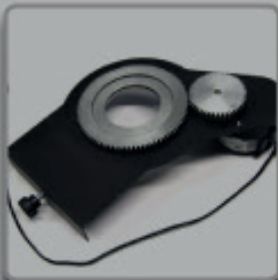



 rotazione
immagine
 image rotation



 specchio
motorizzato
 rotation with
motorized mirror



 Filtro colore
diam 70 mm
 dichroic coloured
filter 70 mm
diameter



FLIGHT CASE

 PREZZO NETTO
 NET PRICE



 prisma
 prism



 cambia colore
continuo + 6 filtri
colore 70 mm
continuous
change color + 6
dichroic filter 70
mm

EFFETTI DINAMICI - DYNAMIC EFFECT

OGNI EFFETTO DINAMICO E' COMPOSTO DA:
EACH DYNAMIC EFFECT IS COMPOSED BY:



+



STANDARDEFFECTS



cod. 020

Neve
Snow



cod. 021 €

Stelle classiche
Classical stars



cod. 022

Stelline
Little Stars



cod. 023

Neve e stelline
Snow & little stars



cod. 052

Fiocchi neve grandi e stelline
Big snow flakes & stars



cod. 030

Scritte auguri in sei lingue + stelline
Best wishes in six languages + stars



cod. 051

Mix di grafiche natalizie
Christmas graphic mix



cod. 028

Caduta puntini neve e stelline
Falling snow & stars





cod. 029

Note
Notes



cod. 033

 Stelle di Natale

 Christmas Stars

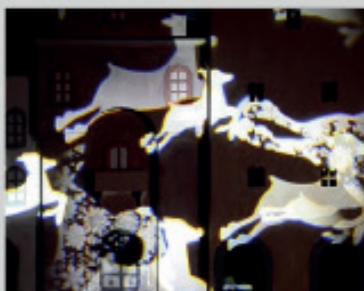

cod. 043

 Renne che saltano

 Reindeers

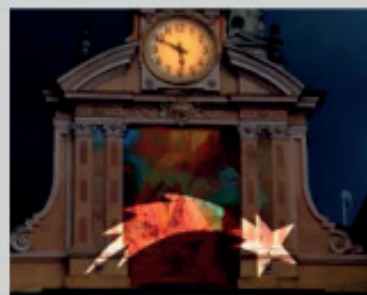

cod. 044

 Passaggio stella cometa

 Christmas comet passage

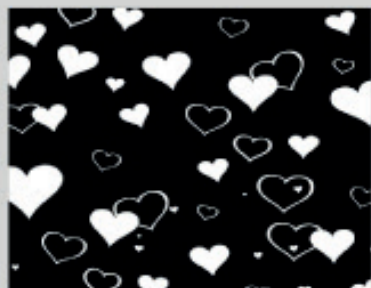

cod. 041

 Cuori

 Hearts

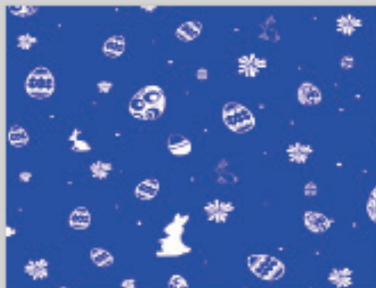

cod. 045

 Pasqua

 Easter



cod. 046

 Carnevale

 Carnival



cod. 047

 Primavera

 Spring



cod. 048

 Autunno

 Autumn

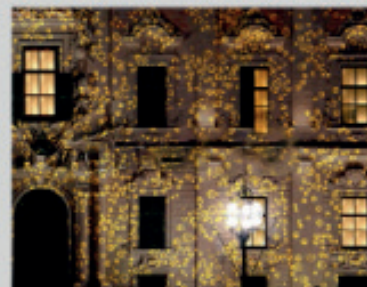

cod. 049

 Bolle

 Bubbles



cod. 054

 Matrimoni

 Wedding



cod. 055

 Estate

 Summer



cod. 200

 Mix Natale Bicolore

 Double colour christmas

OBIETTIVI LENS



INCLUDED!

LENS INCLUDED WITH THE PROJECTOR

ratio 2,6 - 2:1



ONE 4 ALL propone una gamma di ottiche supplementari in grado di soddisfare ogni possibile esigenza per consentire proiezioni ottimali a qualsiasi distanza. Gli obiettivi supplementari permettono di ottenere proiezioni del diametro desiderato a qualsiasi distanza, anche differente da quelle normalmente coperte dall'ottica zoom standard (inclusa in tutti i proiettori) e sono consigliati per una resa ottimale di immagini di qualità fotografica estremamente dettagliate.



ONE 4 ALL offers a range of additional lenses to meet every possible need to allow optimal projections at any distance. The objectives allow us to obtain additional projections of the desired diameter at any distance, even different from those normally covered standard zoom optics (included in all projectors) and are recommended for optimum yield extremely detailed images of photographic quality.



SCEGLI ALTRI OBIETTIVI ADATTI ALLA TUA INSTALLAZIONE:



CHOOSE OTHER LENSES SUITABLE FOR YOUR PROJECTION:



DOWNLOAD THE CALCULATOR

INGRANDITORE MAGNIFER

**GRANDANGOLO (INGRANDITORE + 180+F300+PORTA LENTE)
WIDEANGLE (MAGNIFIER +180 + F300 + LENS HOLDER**

**OBF 180
OBF 222
OBF 300
OBF 500 MONT BLANC**

D-DMX-Controller

ACCESSORI DMX per la sincronizzazione tra piu' proiettori DMX ACCESSORIES for synchronization between many projectors

 IL D-DMX-Controller è una centralina Dedicata per CAMBIO IMMAGINI - COLORE - EFFETTI E DISSOLVENZE. Permette di gestire fino a 4 motori DMX-Motor su cui possono montare effetti dinamici e/o cambia immagine/colore creando suggestive dissolvenze tra le immagini o giochi di colori. Collegabile in serie (MASTER/SLAVE) con altri proiettori dotati di D-DMX-Controller può cambiare colore o immagine contemporaneamente ottenendo un effetto sincronizzato.

 The D-DMX-Controller is a dedicated control unit for CHANGE IMAGES - COLOUR - EFFECTS. It allows you to manage up to 4 engines DMX-MOTOR which can mount dynamic effects and / or change image / colors creating evocative fades between pictures or colors games. Connected in series (MASTER / SLAVE) with other projectors equipped with D-DMX-Controller can change color or image simultaneously obtaining a synchronized effect.



D-DMX-C

-  dispositivo dmx con pannello di controllo
-  dmx device with control panel for managing up to 4 effects (motors)



DMX-MOTOR

-  motore con staffa per ruote
-  motor and support for wheels



cod. H-70

-  ruota per 4 gobos diam. 70 mm otturatore e filtri colore (codice fil70)
-  wheel for 4 gobos diam. 70 mm / shutter and coloured filters (code fil70)



cod. H-50

-  ruota per 6 gobos diam. 50 mm / otturatore e filtri colore (codice filtri fil50)
-  wheel for 5 gobos diam. 50 mm for 6 gobos / shutter and coloured filters (code fil50)

🇮🇹 GOBO STANDARD e PERSONALIZZATI 🇬🇧 STANDARD & CUSTOM GOBOS



🇮🇹 REALIZIAMO gobos con immagini e loghi personalizzati su vetro dicroico. Grazie al laser ad alta definizione, incidiamo su supporto dicroico immagini di altissima qualità.

🇬🇧 WE CREATE custom gobos on dichroic glass. Thanks to high definition laser, we engrave on dichroic support high quality pictures.



Ø 55 mm

Ø 70 mm

○ diametro utile per l'inserimento delle grafica
useful diameter for the layout of logos / texts / pictures

○ diametro del gobo
gobo diameter